

Driven by our customers



**UNIQUE BOSSTON DESIGN FEATURES**

**INTERNAL BOSSTRUT SYSTEM**

Facilitates the easy customisation of internal fit-outs

**FLUSH COAMING FLOOR SYSTEM**

Makes your workspace safe, accessible, and space efficient

**DOOR OPEN SEAL**

Creates a weather proof seal that keeps your workspace dry when door is open

**INTERNAL TRI-ACTION HINGE SYSTEM**

Concealed, adjustable hinge system keeps all moving parts out of the weather and incredibly secure

**Integrated Canopy**



- ▲ Aluminium construction
- ▲ 3 doors
- ▲ Painted to match cab
- ▲ Suits most extra cab utes
- ▲ Optional front and rear windows
- ▲ Weight 270kg

**PART NO. ISC900**

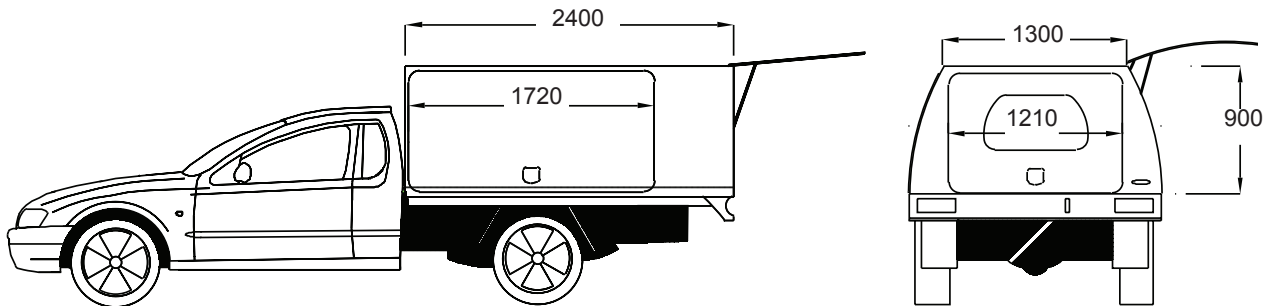

**FITOUT OPTIONS**

See the accessories section or our catalogue or website for even more options...

**External**

- Roof racks
- Roller drawers
- Ladders/rope rails
- Underbody Boxes
- Wheel carriers/holders

**Internal**

- Vices
- Drawer systems/rola cases
- Fold down work benches
- Shelves and dividers
- Shelving Kits with bins

**Electrical**

- Beacons
- Door alarms
- Reversing sensors
- Remote central locking
- Mine spec light bars

**PERTH METRO**

4 Tacoma Circuit  
CANNING VALE WA 6155  
P 1300 551 998  
F 1300 551 686  
E sales@bosston.com.au

**WA REGIONAL**

1 Great Eastern Highway  
CUNDERDIN WA 6407  
P 1300 551 998  
F 1300 551 686  
E sales@bosston.com.au

**NSW-VIC**

17 O'Sullivan Place  
GOULBURN NSW 2580  
P 1300 551 998  
F 1300 551 686  
E sales@bosston.com.au

**WWW.BOSSTON.COM.AU**